

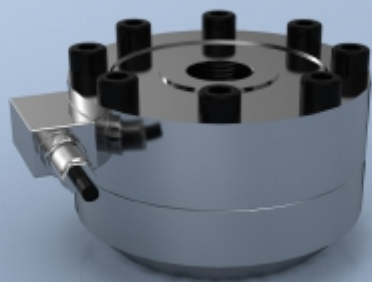

TYPE: PTC-1



PTC-1 Stainless Steel Low Profile Universal Load Cell

Description

The PTC-1 series of load cells are based on the conventional low profile or pancake load cell principle. The internal construction is a diaphragm design, offering a lower cost solution to conventional shear web designs, while still offering high natural frequency, low deflection and excellent resistance to side and torsion forces. The PTC-1 is constructed from stainless steel to give excellent corrosion protection. There is an optional mounting base available, which is required if the load cell is to be used in tension. The mounting base is also constructed from stainless steel.

The standard load cell is supplied with an integral cable and the facility to attach a protective hose or conduit. It is ideally suited to many testing applications where high stability and low height are essential requirements, the PTC-1 can be supplied calibrated as a complete ready-to-go system. Also available is a range of associated instrumentation.

Specification

Rated load (kN)	2.5, 5, 10, 25, 50, 100, 200, 300, 500, 750, 1000, 2000, 3000, 5000				
Accuracy class	ISO 376 class 1				
Relative Error: Reproducibility	≤±0.145% down to 10% of rated load				
Repeatability	≤±0.1% down to 10% of rated load				
Interpolation	≤±0.09% down to 10% of rated load				
Reversibility	≤±0.24% down to 10% of rated load				
Zero	≤±0.03% FSO				
Linearity	≤±0.05% FSO (≤±0.1% FSO 2000kN-5000kN versions)				
Hysteresis	≤±0.05% FSO (≤±0.1% FSO 2000kN-5000kN versions)				
Temperature effect on zero	≤±0.0028% of rated load per °C				
Temperature effect on sensitivity	≤±0.0024% of rated load per °C				
Effect of transverse loads at 10% FSO	≤±0.03% of rated load				
Nominal sensitivity	2mV/V				
Sensitivity tolerance	≤±0.1% FSO				
Input resistance	5kN to 500kN: 800Ω ±20Ω 750kN to 5000kN: 430Ω ±20Ω				
Output resistance	5kN to 500kN: 705Ω ±2Ω 750kN to 5000kN: 352Ω ±2Ω				
Insulation resistance	>5GΩ				
Zero balance	≤±1% FSO				
Recommended supply voltage	10V (1-15V nominal, 18V maximum)				
Service load	120%				
Maximum permissible load	150%				
Breaking load	>300%				
Maximum traverse load	100%				
Maximum permissible dynamic load	75%				
Displacement at nominal load (kN)	2.5-25kN	50-100kN	200-500kN	750-1000kN	2000-5000kN
	~0.06mm	~0.09mm	~0.17mm	~0.23mm	~0.21mm
Temperature nominal range	-10 to +40°C				
Service temperature	-10 to +70°C				
Storage temperature	-20 to +80°C				
Environmental protection level	IP67				
Electrical connections	5 metres PVC cable				
Wiring connections: 2.5kN - 1000kN	+ve supply: Red				-ve supply: Black
PVC 4-core cable	+ve signal: White				-ve signal: Yellow
Wiring connections: 2000kN - 5000kN	+ve supply: Red				-ve supply: Black
PVC 6-core cable	+ve sense: Orange				-ve sense: Blue
	+ve signal: White				-ve signal: Yellow

Features

- Ranges from 2.5 to 5000kN
- Stainless steel construction
- Environmentally sealed to IP67
- Low profile
- Hose/conduit fitting facility as standard
- High thermal stability
- High natural frequency

Typical Applications

- Structural testing
- Jack load monitoring
- Airframe testing
- Material test machine feedback
- Fatigue testing rigs

Available Options

- Mounting base
- TEDS option (when used with TR150 handheld display)
- Load cap assembly
- Connector version (M12 or MIL spec)

PTC-1 Stainless Steel Low Profile Universal Load Cell

Dimensions

All dimensions are in mm

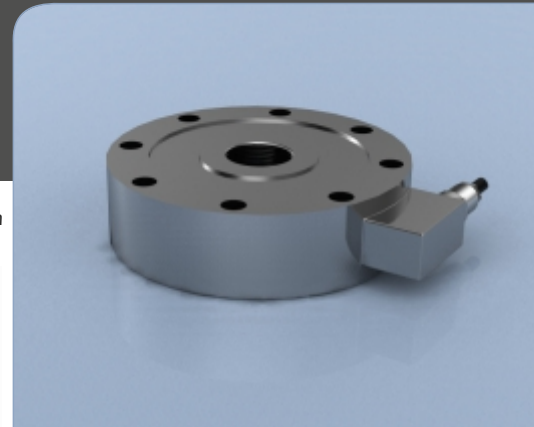
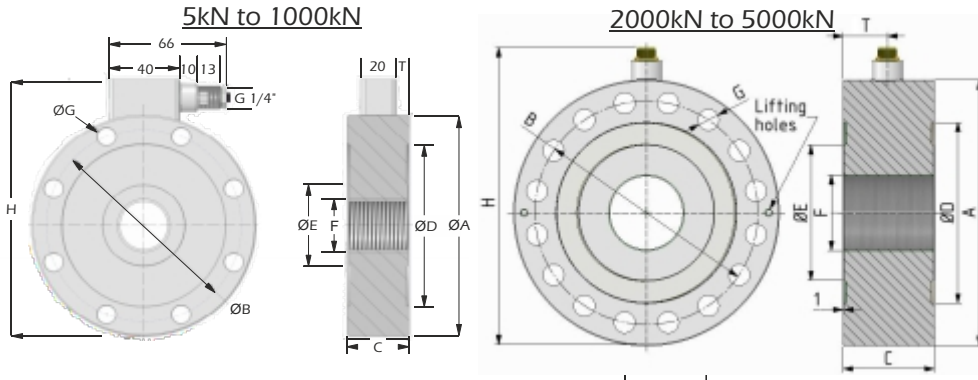

Rating (kN)	ØA	ØB	C	ØD	ØE	F	ØG	H	T	kHz *	Weight (kg)	Resolution
2.5	100	86	35	72	32	M20 x 1.5	6 holes Ø9	121	7.5	2.5	1.6	0.0005
5	100	86	35	72	32	M20 x 1.5	6 holes Ø9	121	7.5	2.5	1.6	0.001
10	100	86	35	72	32	M20 x 1.5	6 holes Ø9	121	7.5	2.5	1.6	0.002
25	100	86	35	72	32	M20 x 1.5	6 holes Ø9	121	7.5	4.8	1.6	0.005
50 ⁽¹⁾	100	86	35	72	32	M20 x 1.5	6 holes Ø9	121	7.5	8.6	1.6	0.01
50	127	110	35	92	47	M30 x 2	8 holes Ø10.5	149	7.5	3.8	2.5	0.01
100	127	110	35	92	47	M30 x 2	8 holes Ø10.5	149	7.5	5.8	2.5	0.02
200	165	138	50	108	62	M42 x 3	12 holes Ø17	188	15	5.7	5.8	0.05
300	165	138	50	108	62	M42 x 3	12 holes Ø17	188	15	7.3	5.8	0.1
500	165	138	60	108	62	M42 x 3	12 holes Ø17	188	20	9.8	6.8	0.1
750	230	185	80	145	98	M60 x 3	12 holes Ø26	254	30	3.2	16.5	0.2
1000	230	185	80	145	98	M60 x 3	12 holes Ø26	254	30	3.2	16.5	0.2
2000	300	250	100	198	132	M100 x 3	16 holes Ø25	339	50	2.7	35	0.5
3000 ⁽²⁾	350	294	120	238	178	M100 x 3	16 holes Ø28	389	60	2.8	63	1
5000 ⁽²⁾	350	294	130	238	178	M100 x 3	16 holes Ø28	389	65	2.8	63	1

(1) Suitable for use in tension up to 25kN (2) Suitable for use in tension up to 2500kN * Natural frequency

Note: Default calibration of these load cells will be in compression. If you require calibration in tension or both tension & compression, please state at time of order (additional charges may apply).

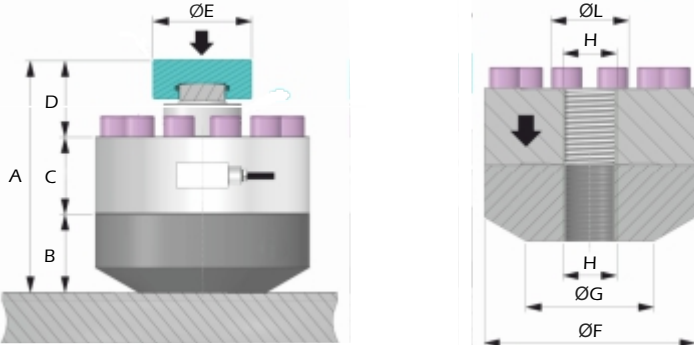

Rating kN	A	B	C	D	ØE	ØF	ØG	H	ØL
2.5, 5, 10, 25, 50	108	37	35	36	57	100	70	M20 X 1.5	32
50, 100	108	37	35	36	76	127	100	M30 X 2	47
200, 300	169	60	50	59	76	165	100	M42 X 3	62
500	179	60	60	59	76	165	100	M42 X 3	62
750, 1000	252	85	80	87	126	230	180	M60 X 3	98
2000	309	85	100	124	129	300	250	M100 X 3	132
3000	384	120	120	144	168	350	330	M100 x 3	178
5000	394	120	130	144	168	350	330	M100 x 3	178

For optimum performance, LCM Systems recommends 12.9 grade socket head cap screws to bolt down the load cell to any mounting assemblies. The bolts should be tightened to the torques shown in the table below. If a load cell is ordered with an optional mounting base, then this will be supplied pre-assembled and torqued down.

Bolt size	M8	M10	M16	M24	M27
Tightening torque	40Nm	70Nm	368Nm	460Nm	1500Nm